

500-EXCELLENT SERIES HK-MODELS



Contactor with motor protector

Jam release wrench
for grinding unit

Disperator food waste disposers are installed in kitchens and galleys to remove food waste immediately from areas where it is produced.

When assembled with an HK mounting assembly, a Disperator 500 Excellent Series food waste disposer can be installed in a table or working top. Unlike the MI assembly, the HK assembly permits continuous feeding of waste into the disposer. The opening into the disposer is partly covered enabling food waste to enter the grinding unit but preventing accidental access to the rotating grinding unit during operation.

The HK mounting assembly has three flushing nozzles mounted on the inside of the cone. These are connected to a solenoid valve and a line strainer. When the disposer is started, the solenoid valve opens allowing water to flush food waste into the grinding unit and out to the wastewater system.

The Disperator 500 Excellent Series has Det Norske Veritas (DNV) Approval for compliance with IMO MARPOL 73/78 ANNEX V for disposal of ground food waste into the open sea.

Further details are specified overleaf.

Disperator AB

Mälurvägen 9, SE-141 71 Segeltorp, Sweden
Tel +46 8 724 01 60, Fax +46 8 724 60 70
info@disperator.se, www.disperator.se



MADE IN SWEDEN

Ref: HK/Prod/Eng/091014

500-EXCELLENT SERIES HK-MODELS

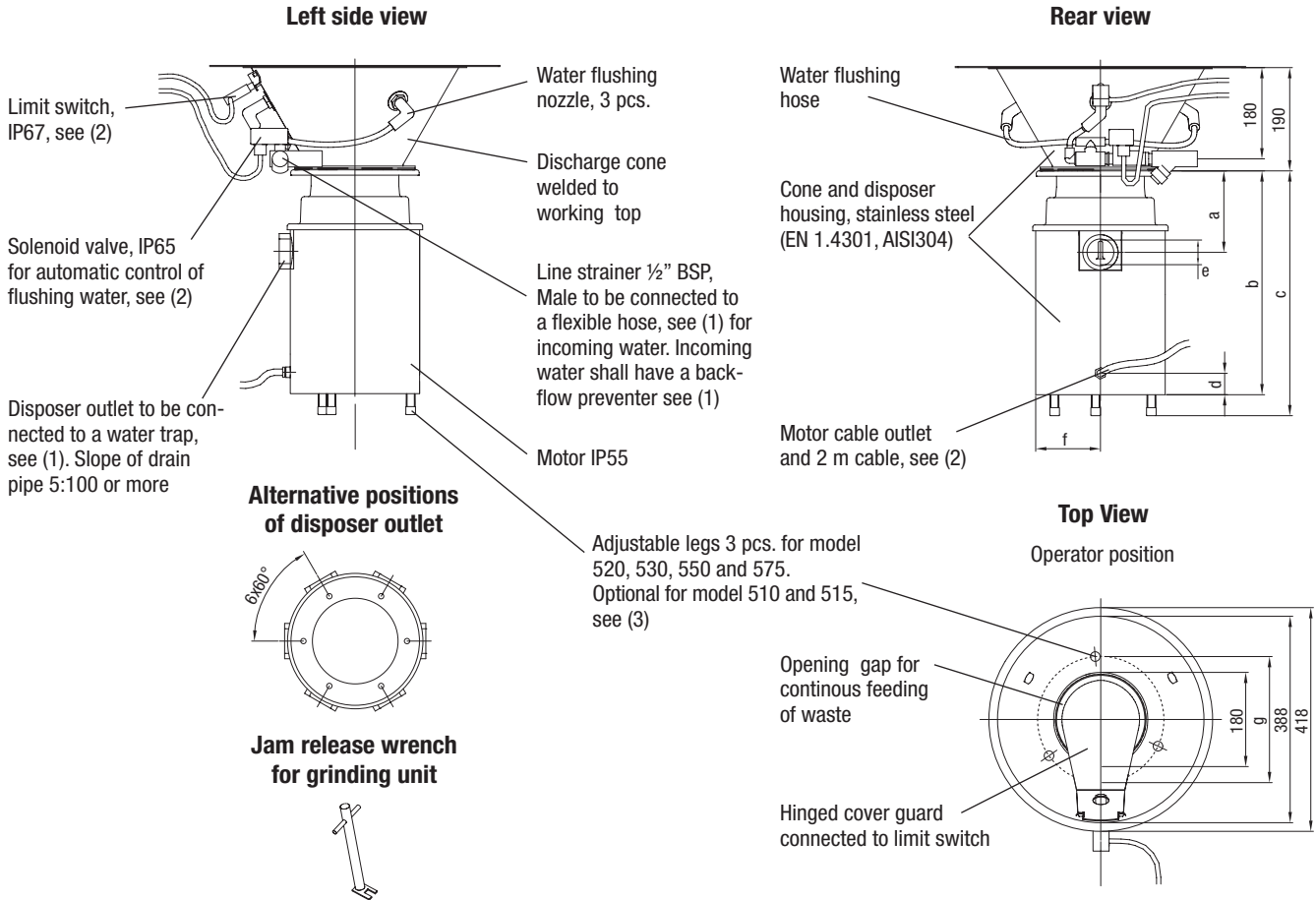

All measurements in mm

Technical Specification	510-HK	515-HK	520-HK	530-HK	550-HK	575-HK
Normal capacity, kg/hr	300	400	500	700	850	1000
Electrical power, kW	0,75	1,1	1,5	2,2	4,0	5,5
Rated current, A for:						
230 V / 3 ph. / 50 Hz	3,7	4,6	5,9	9,0	14,4	19,7
400 V / 3 ph. / 50 Hz	2,1	2,6	3,4	5,2	9,0	11,5
440 V / 3 ph. / 60 Hz	2,1	2,4	3,5	5,2	7,5	11,6
Other 3-ph voltages available	1-ph 220-240V, 50/60Hz also available for models 510 and 515					
Control voltage	For marine installation the same as motor voltage. For land installation 230V / 50HZ					
Fuse rating, slow	10 A	10 A	10 A	16 A	16 A	25 A
Gross / net weight, kg	38 / 32	41 / 35	46 / 40	54 / 48	57 / 51	66 / 60
Measurement a	151	151	151	176	176	176
Measurement b	425	425	568	545 see (4)	545 see (4)	640
Measurement c	See (3)	See (3)	591-715	570-635 see (4)	570-635 see (4)	665-730
Measurement d	40	40	40	75	75	75
Measurement e	2"	BSP,	Female	2 1/2"	BSP,	Female
Measurement f	127	127	127	155	155	155
Measurement g (legs)	See (3)	See (3)	204	236	236	236

- (1) Installation material needed but not incl. in standard delivery are electrical connection terminal / main switch, flexible hose 1/2", backflow preventer and water trap. Can be ordered from DISPERATOR.
- (2) For connection to start & stop controller (IP55, incl. overload protector) placed on wall / bulkhead. Controller to be connected to terminal / main switch, see (1).
- (3) 3-ph standard without legs. Legs available as option – and then with same measurements b), c) and g) as model 520. Models 510, 515 1-ph have same measurements b), c) and g) as model 520.
- (4) Short version (b = 510 mm and c = 522–593 mm) and longer version (b = 640 mm and c = 665–730 mm) available as option.
- (5) Installation, operation and service instructions are together with this product leaflet included in delivery.

Disperator AB

Mälurvägen 9, SE-141 71 Segeltorp, Sweden
 Tel +46 8 724 01 60, Fax +46 8 724 60 70
 info@disperator.se, www.disperator.se